

Features

- CMOS Technology for Bus and Analog Applications
- Low On-Resistance: 0.6Ω.
- V_{CC} Range: 1.8V to 4.2V
- Rail-to-Rail Signal Range
- High Off Isolation: -75dB @ 100kHz
- Crosstalk Rejection: -90dB @ 100kHz
- Break-Before-Make Switching
- Extended Industrial Temperature Range: -40°C to 85°C
- LoPro® Packaging (Pb-free): 10-Lead Micro Package

Applications

- Cell Phones
- PDAs
- MP3 players
- Portable Instrumentation
- Computer Peripherals
- Speaker Headset Switching
- Power Routing
- Relay Replacement
- Audio and Video Signal Routing
- PCMCIA Cards
- Modems

Pin Descriptions

Pin No.	Name	Description
1,3	NO _x	DATA Port (Normally Open)
4	GND	Ground
10,2	NC _x	DATA Port (Normally Closed)
8,5	COM _x	Common Port / DATA Port
9	V _{CC}	Positive Power Supply
7,6	IN _x	Logic Control

Logic Function Table

Logic Input (IN _x)	Function
0	NC _x Connected to COM _x
1	NO _x Connected to COM _x

Description

ProTek Analog's PA2268 is a dual high-bandwidth, fast single-pole double throw (SPDT) CMOS switch. It can be used as an analog switch or as a low-delay bus switch. Specified over a operating power supply voltage, 1.8V to 4.2V, the PA2268 has an On-Resistance of 0.6Ω at +2.7V. Break-before-make switching prevents both switches being enabled simultaneously. This eliminates signal disruption during switching.

The PA2268T includes termination resistors that improve noise immunity during overshoot excursions and off isolations or pop-up noise minimization

Functional Block Diagrams

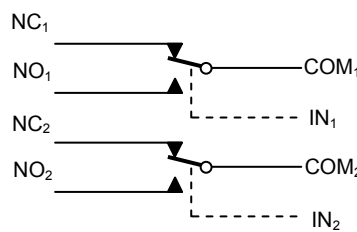

Fig. 1 PA2268

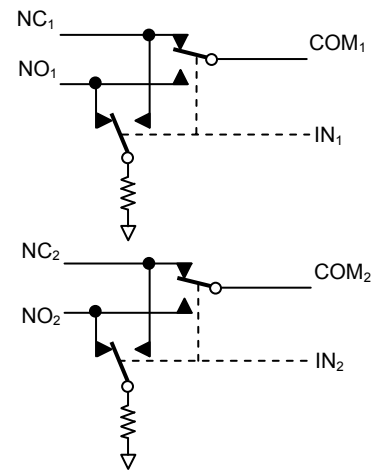
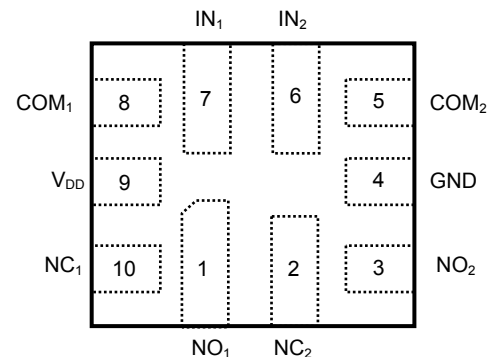

Fig.2 PA2268T (with termination resistors)

Pin Configuration (Top View)



Ordering Information

Temperature Range	Package	Part Number
-40 to 85 °C	10 Lead LoPro	PA2268-T7
-40 to 85 °C	10 Lead LoPro	PA2268T-T7

Absolute Maximum Ratings⁽¹⁾

Supply Voltage V_{CC}	4.5V
DC Switch Voltage (VS) ⁽²⁾	$V_{CC} + 0.5V$
DC Input Voltage (VIN) ⁽²⁾	4.5V
Analog Signal Range.....	Min -1.0 to Max $V_{CC} + 1.0$
Continuous Current NO_NC_COM_	$\pm 300mA$ Peak
Current NO_NC_COM_	$\pm 300mA$ Peak
(pulsed at 1ms 50% duty cycle)	$\pm 400mA$ Peak
Current NO_NC_COM_	$\pm 500mA$
(pulsed at 1ms 10% duty cycle)	$\pm 500mA$
Storage Temperature Range (TSTG) ..	$-65^{\circ}C$ to $+150^{\circ}C$
Junction Temperature under Bias (TJ).....	$150^{\circ}C$
Junction Lead Temperature (TL)	$260^{\circ}C$
(Soldering, 10 seconds).....	$260^{\circ}C$
Power Dissipation (PD) @ $+85^{\circ}C$	$250mW$

Recommended Operating Conditions⁽³⁾

Supply Voltage Operating (V_{CC})	1.8V to 4.2V
Control Input Voltage (V_{IN}).....	0V to V_{CC} Switch Input
Voltage (V_{IN}).....	$-0.3V$ to V_{CC} Output Voltage
(V_{OUT}).....	0V to V_{CC}
Operating Temperature (T_A).....	$-40^{\circ}C$ to $+85^{\circ}C$
Input Rise and Fall Time (t_r, t_f)	
Control Input $V_{CC} = 2.3V - 3.6V$	0ns/V to 10ns/V
Thermal Resistance (θ_{JA}).....	$350^{\circ}C/W$
Lead Temperature (soldering 10s).....	$+240^{\circ}C$
Bump Temperature (soldering notes)	
Infrared (15s).....	$+220^{\circ}C$
Vapor Phase (60ns).....	$+215^{\circ}C$

Notes:

1. "Absolute Maximum Ratings" may cause permanent damage to the device. This is a stress only rating and operation of the device at these or any other conditions beyond those indicated in the operational sections of this specification is not implied.
2. The input and output negative voltage ratings may be exceeded if the input and output diode current ratings are observed.
3. Control input must be held HIGH or LOW; it must not float.
4. Internal Resistance R_{TERM} is guaranteed by design and not production tested.

Capacitance

Parameter	Symbol	Test Conditions	Min	Typ	Max	Unit
NC Off Capacitance	$C_{NC(OFF)}$	$f = 1MHz$, See Test Circuit Figure7.		35		pF
NO Off Capacitance	$C_{NO(OFF)}$	$f = 1MHz$, See Test Circuit Figure7.		35		
NC On Capacitance	$C_{NC(ON)}$	$f = 1MHz$, See Test Circuit Figure8.		95		
NO On Capacitance	$C_{NO(ON)}$	$f = 1MHz$, See Test Circuit Figure8.		95		

DC Electrical Characteristics +3V Supply
(V_{CC} = 2.7V to 3.3V, T_A = -40°C to 85°C, unless otherwise noted. Typical values are at 3V and +25°C.)

Parameter	Symbol	Test Conditions	Min	Typ	Max	Unit
Analog Switch						
Analog Signal Range	V _{NO} , V _{NC} , V _{COM}		-0.3		V _{CC}	V
NC On-Resistance	R _{ON(NC)}	V _{CC} = 2.7V, I _{COM} = 100mA, V _{NC} = 0 to V _{CC}		0.4	0.6	Ω
NO On-Resistance	R _{ON(NO)}	V _{CC} = 2.7V, I _{COM} = 100mA, V _{NO} = 0 to V _{CC}		0.4	0.6	
On-Resistance Match Between Channels	ΔR _{ON}	V _{CC} = 2.7V, I _{COM} = 100mA, V _{NO} or V _{NC} = 1.5V		0.01	0.05	
NC On-Resistance Flatness	R _{ONF(NC)}	V _{CC} = 2.7V, I _{COM} = 100mA, V _{NC} = 0 to V _{CC}			0.2	
NO On-Resistance Flatness	R _{ONF(NO)}	V _{CC} = 2.7V, I _{COM} = 100mA, V _{NO} = 0 to V _{CC}			0.2	
Internal Termination Resistors	R _{TERM}			200		
NO or NC Off Leakage Current	I _{OFF(NO)} or I _{OFF(NC)}	V _{CC} = 3.3V, I _{COM} , V _{NO} or V _{NC} = 3.0V, 0.3V V _{COM} = 0.3V, 3.0V	-20		20	nA
COM On Leakage Current	I _{COM(ON)}	V _{CC} = 3.3V, I _{COM} , V _{NO} or V _{NC} = 3.0V, 0.3V V _{COM} = 0.3V, 3.0V or Floating	-20		20	
Digital I/O						
Input Logic High	V _{IH}		1.3			V
Input Logic Low	V _{IL}				0.5	
Input Hysteresis	V _H	V _{CC} = 3.3V		300		mV
IN Input Leakage Current	I _{IN}	V _{IN} = 0 or V _{CC}	-0.5		0.5	μA
Supply Current	I _{CC}	V _{CC} = 3.6V, V _{IN} = 0 or V _{CC}		0.9	1.2	nA

Switch and AC Characteristics

Parameter	Symbol	Test Conditions	Min	Typ	Max	Unit
Turn-On Time	t _{ON}	V _{CC} = 2.7V, V _{NO} or V _{NC} = 1.5V, R _L = 50Ω, C _L = 35pF. See Test Circuit Figure 1 & 2		15	25	nS
Turn-Off Time	t _{OFF}	V _{CC} = 2.7V, V _{NO} or V _{NC} = 1.5V, R _L = 50Ω, C _L = 35pF. See Test Circuit Figure 1 & 2		4	10	
Break-Before-Make Delay	t _{BBM}	V _{CC} = 2.7V, V _{NO} or V _{NC} = 1.5V, R _L = 50Ω, C _L = 35pF. See Test Circuit Figure 3			20	
Charge Injection	Q	COM = 0, R _S = 0, C _L = 1nF. V _{GEN} = 0 See Test Circuit Figure 4		55		pC
Off-Isolation	Q _{IRR}	C _L = 5pF, R _L = 50Ω, f = 100kHz, V _{COM} = 1V _{RMS} See Test Circuit Figure 5		-75		dB
Crosstalk	X _{TALK}	C _L = 5pF, R _L = 50Ω, f = 100kHz, V _{COM} = 1V _{RMS} See Test Circuit Figure 6		-90		
3dB Bandwidth	f _{3dB}	See Test Circuit Figure 9		100		MHz

Typical Characteristics

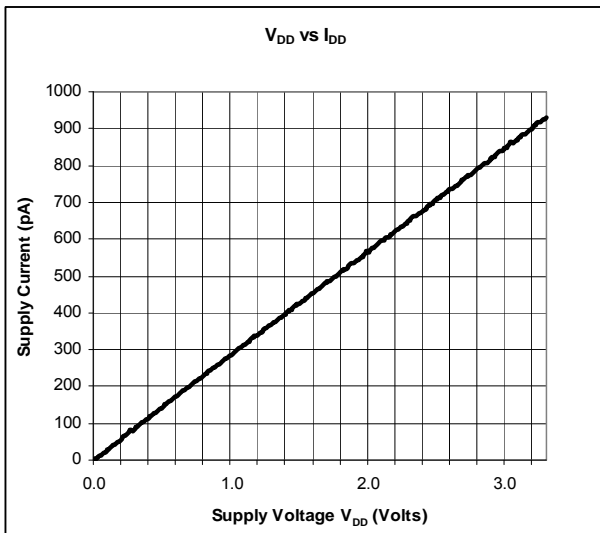
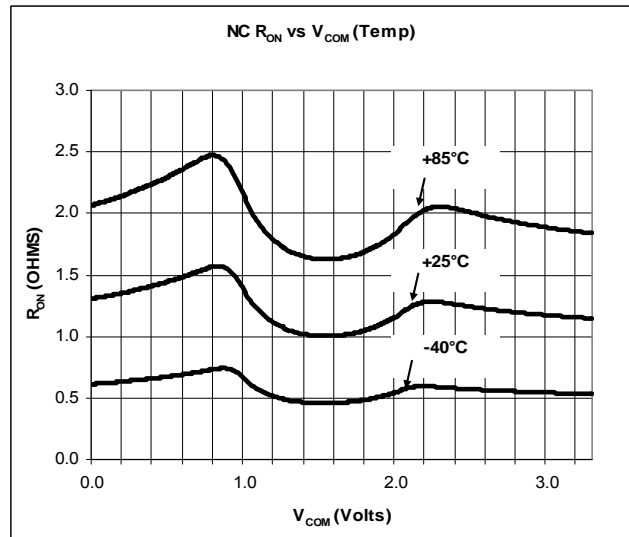
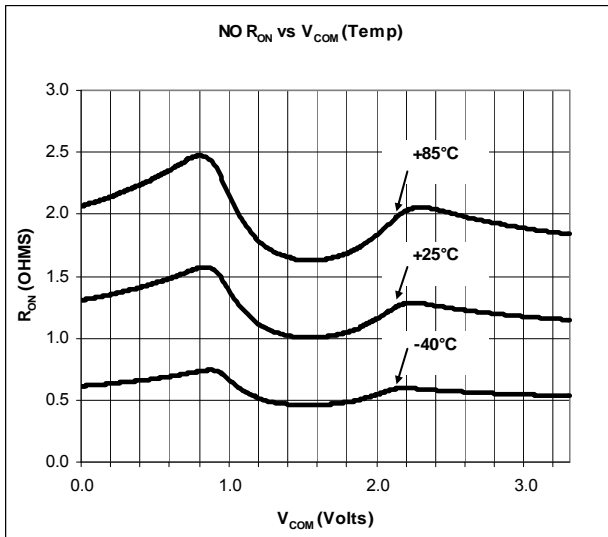
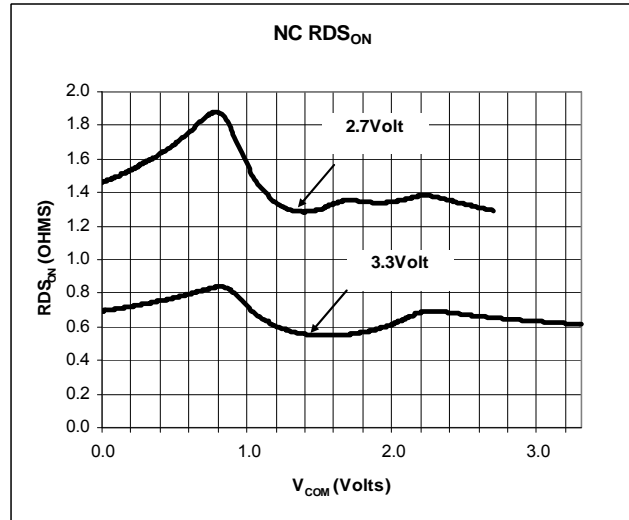
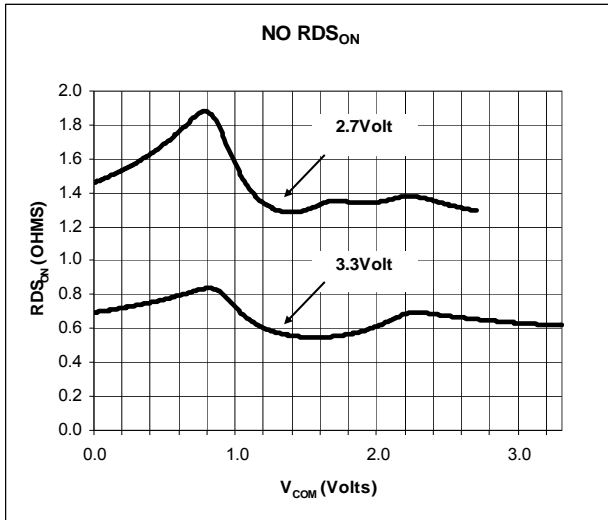

Note: Characteristics are guaranteed by design and are not production tested.

Test Circuits and Timing Diagrams

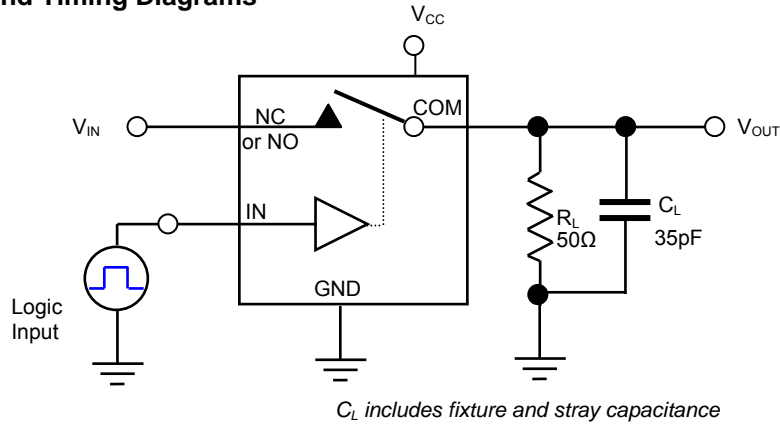
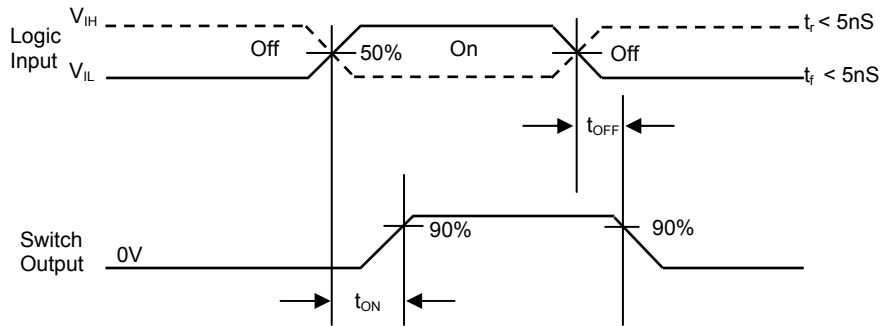

Figure 1. AC Test Circuit

Note1. Unused Input (NO or NC) must be grounded



Logic Input Waveforms inverted for Switches that have opposite logic

Figure2 AC Waveforms

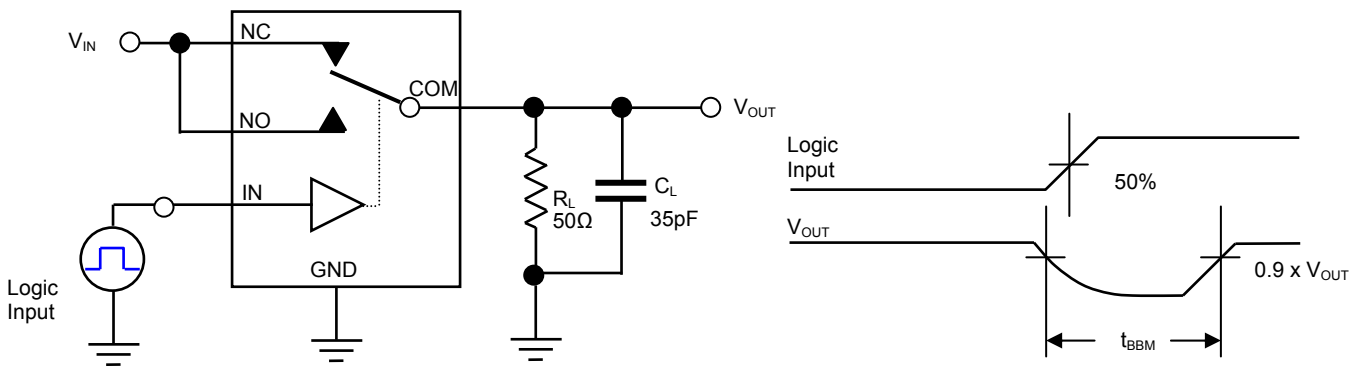

Figure 3. Break Before Make Interval Timing

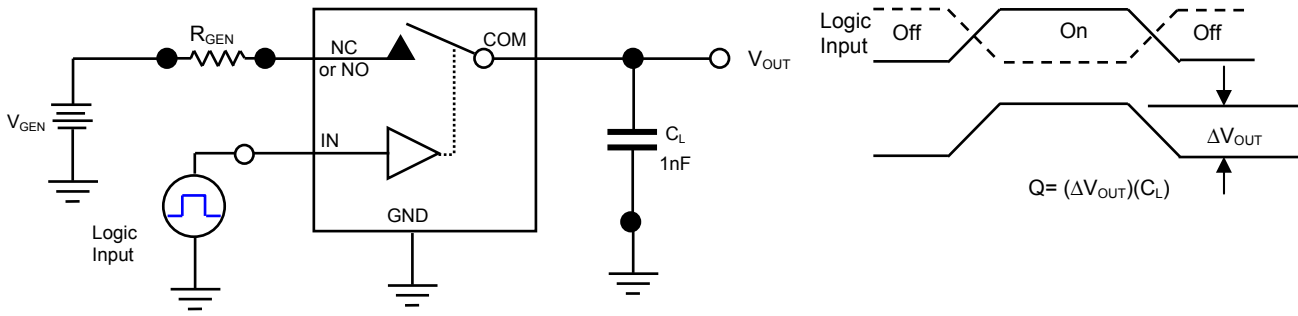

Figure 4. Charge Injection Test

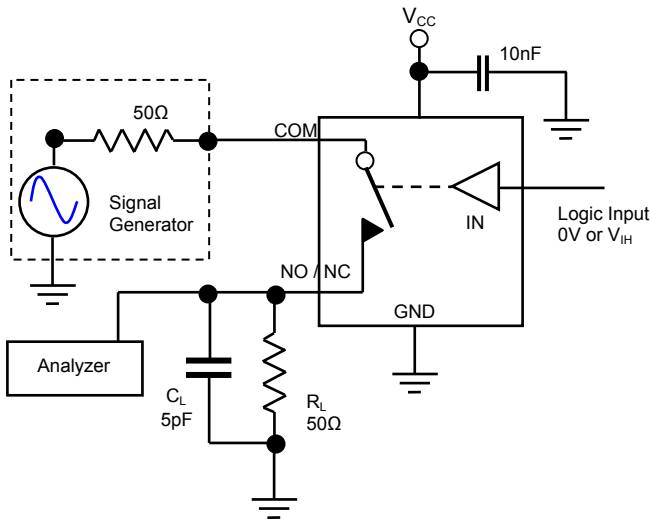

Figure 5. Off Isolation

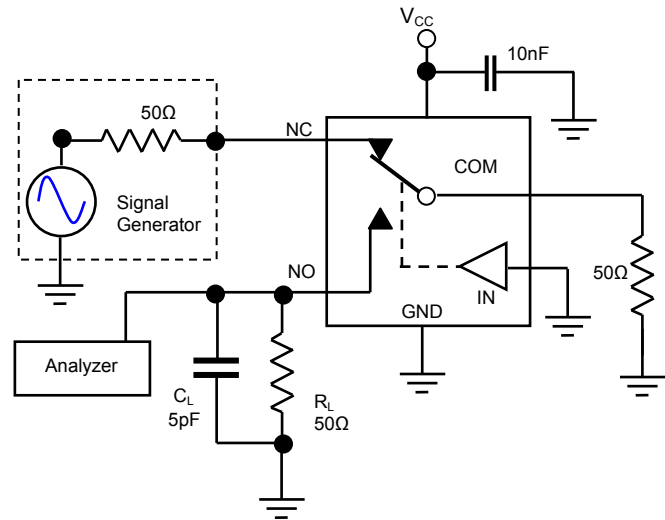

Figure 6. Crosstalk

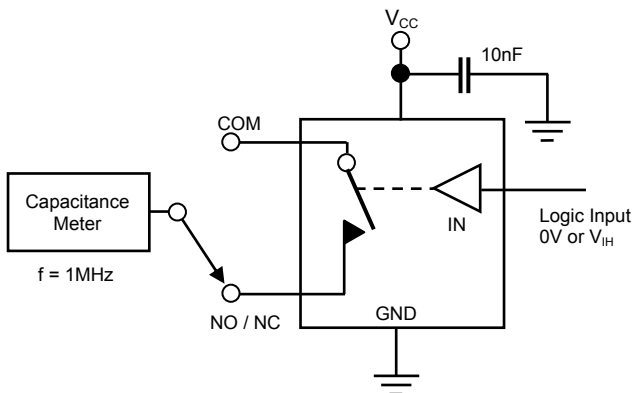

Figure 7. Channel Off Capacitance

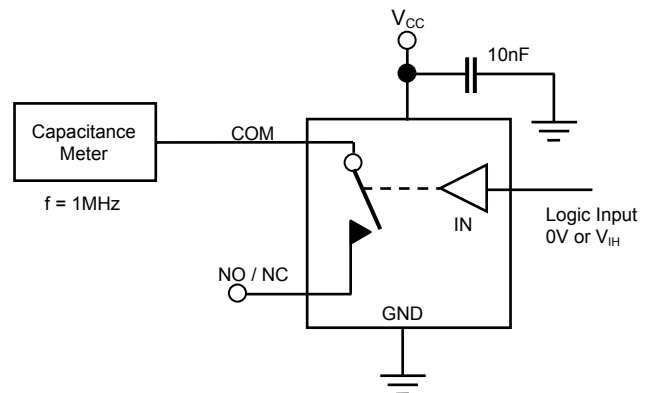

Figure 8. Channel On Capacitance

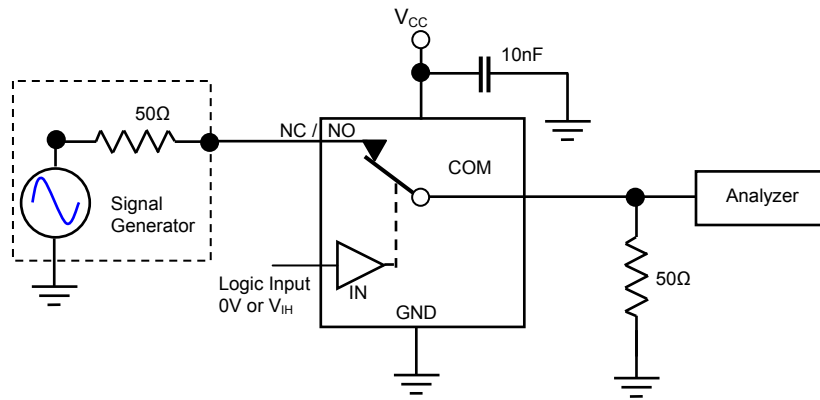
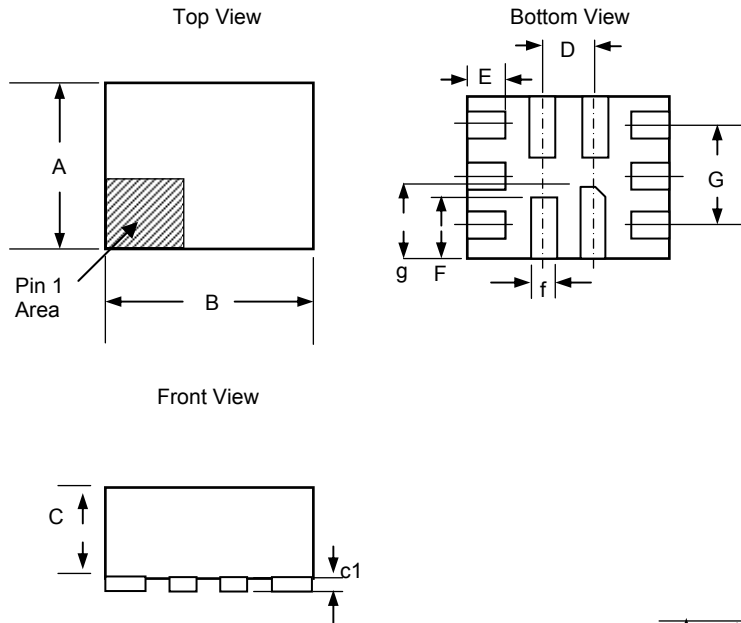

Figure 9. Bandwidth

Package Layout and Dimensions



DIM	MIN	TYP	Max
A	1.25	1.30	1.35
B	1.55	1.60	1.65
C	0.50	0.55	0.60
D	0.40		
E	0.29	0.30	0.31
F	0.49	0.50	0.51
G	0.80 REF		
c	0.00 - 0.05		
c1	0.10 REF		
f	0.15	0.20	0.25
g	0.59	0.60	0.61

Note: Package Dimensions in millimeters

Recommended Land Pattern

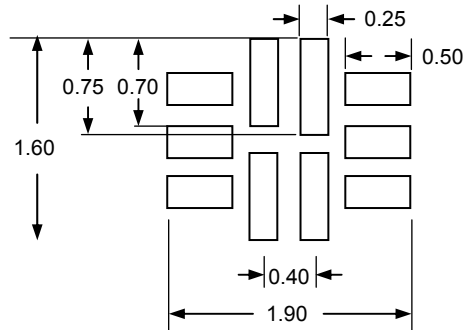

Tape and Reel Specifications

Reel Dia	A0	B0	K0	D	E	F	W	P0	P2	P	t-max
178 (7")	1.47±0.05	1.73±0.05	0.65±0.05	1.50±0.10	1.75±0.10	3.50±0.05	12.00±0.30	4.00±0.10	2.00±0.05	4.00±0.10	0.25

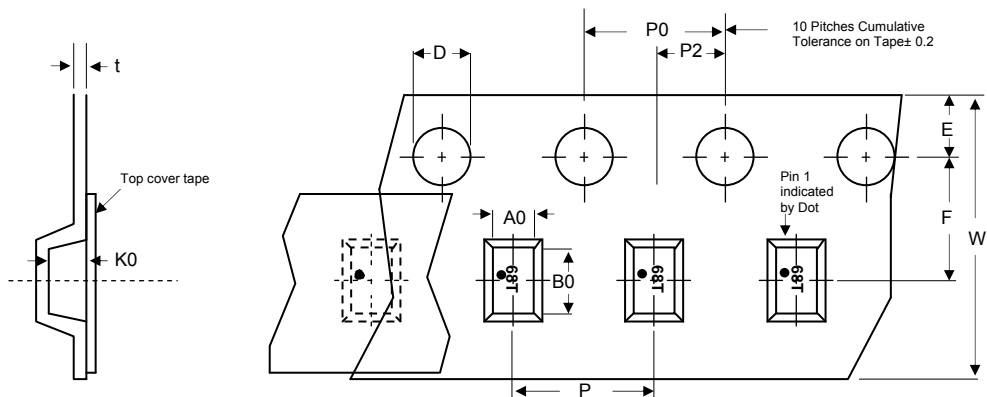

Life Support Policy

PROTEK ANALOG'S PRODUCTS ARE NOT AUTHORIZED FOR USE AS CRITICAL COMPONENTS IN LIFE SUPPORT DEVICES OR SYSTEMS WITHOUT THE EXPRESS WRITTEN APPROVAL OF THE PRESIDENT OF PROTEK DEVICES.