

PACKING DESCRIPTION

ProTek's DFN-10 3.0x3.0x0.85mm 10-Lead products are classified under Moisture Sensitive Level 1.

The carrier tape is made from carbon filled polycarbonate. The cover tape is a transparent, two-sided static dissipative, polyester film tape with heat activated adhesive. The cover tape typical width is 9.50mm. These reeled parts in standard option are shipped with 1000 units per 178 mm (7") diameter reel and 2500 units per 330mm (13") diameter reel. The reels are made of polystyrene plastic (anti-static coated or intrinsic).

The full reels are barcode labeled and placed inside a box with a ProTek™ label printing. The reel is packed inside a vacuum sealed anti-static recyclable plastic bag in the box. If the bag is transparent the label appears only on the reel. Up to ten (10) such sealed bags are placed inside a barcode labeled shipping box. Standard dimensions of the box are 8"x8"x8" for 178mm (7") diameter reels and 14"x14"x14" for 330mm (13") diameter reels.

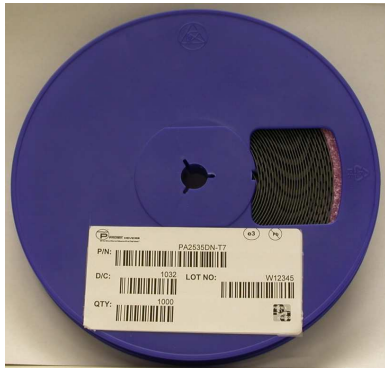

178mm Reel with ProTek Barcode



330mm Reel with ProTek Barcode

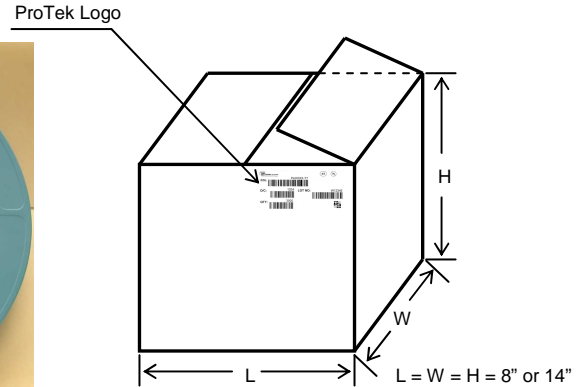

Box showing dimensions and ProTek Label



ProTek Packaging Box showing Label

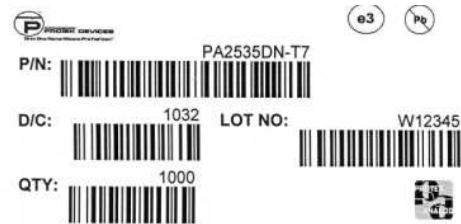

ProTek Label T7 reel (1000 units)



ProTek Label T13 reel (2500 units)

DFN 10 CARRIER TAPE DIMENSION (Not drawn to scale)

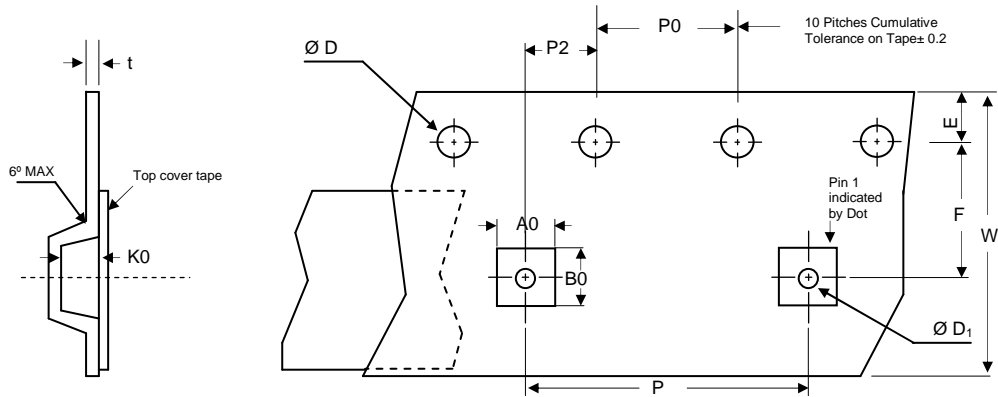

Reel Dia	A0	B0	K0	D	D1	E	F	W	P0	P2	P	t-max
178 (7") or 330 (13")	3.35±0.10	3.35±0.10	1.13±0.10	1.50+0.10	1.50+0.25	1.75±0.10	5.50±0.05	12.00±0.30	4.00±0.10	2.00±0.05	8.00±0.10	0.25±0.02

Notes:

- All Dimensions in millimeters unless otherwise noted
- A0, B0, and K0 dimensions are determined with respect to the EIA /Jedec RS-481 rotational and lateral movement requirements (see sketches A, B, and C).
- Suffix - T7 = 178mm (7") Reel - 1,000 pieces per 12mm tape.
- Suffix - T13 = 330mm (13") Reel - 2,500 pieces per 12mm tape.

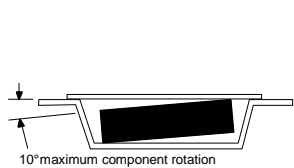

Sketch A (Side or Front Sectional View)
Component Rotation

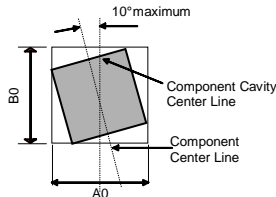

Sketch B (Top View)
Component Rotation

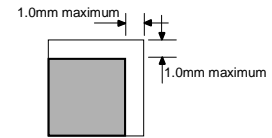

Sketch C (Top View)
Component Lateral Movement

SHIPPING REEL DIMENSION

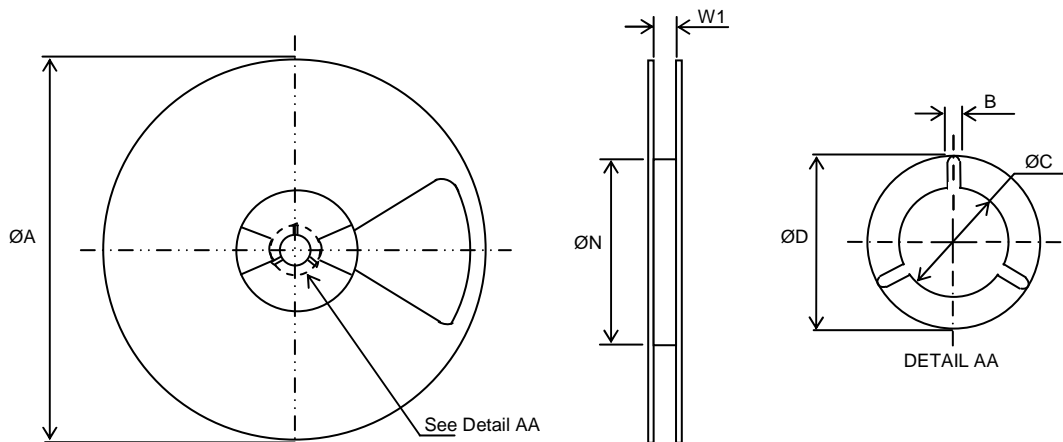

Tape Width	Reel Size	A max	B min	C	D min	W1 +2.0/-0.0	N min
12	178	180.0	1.5	13±0.2	20.2	12.4	60.0
	330	332.0	1.5	13±0.2	20.2	12.4	62.0

Notes:

- Dimensions in millimeters

DFN-10 PACKAGE OUTLINE (Not drawn to scale)

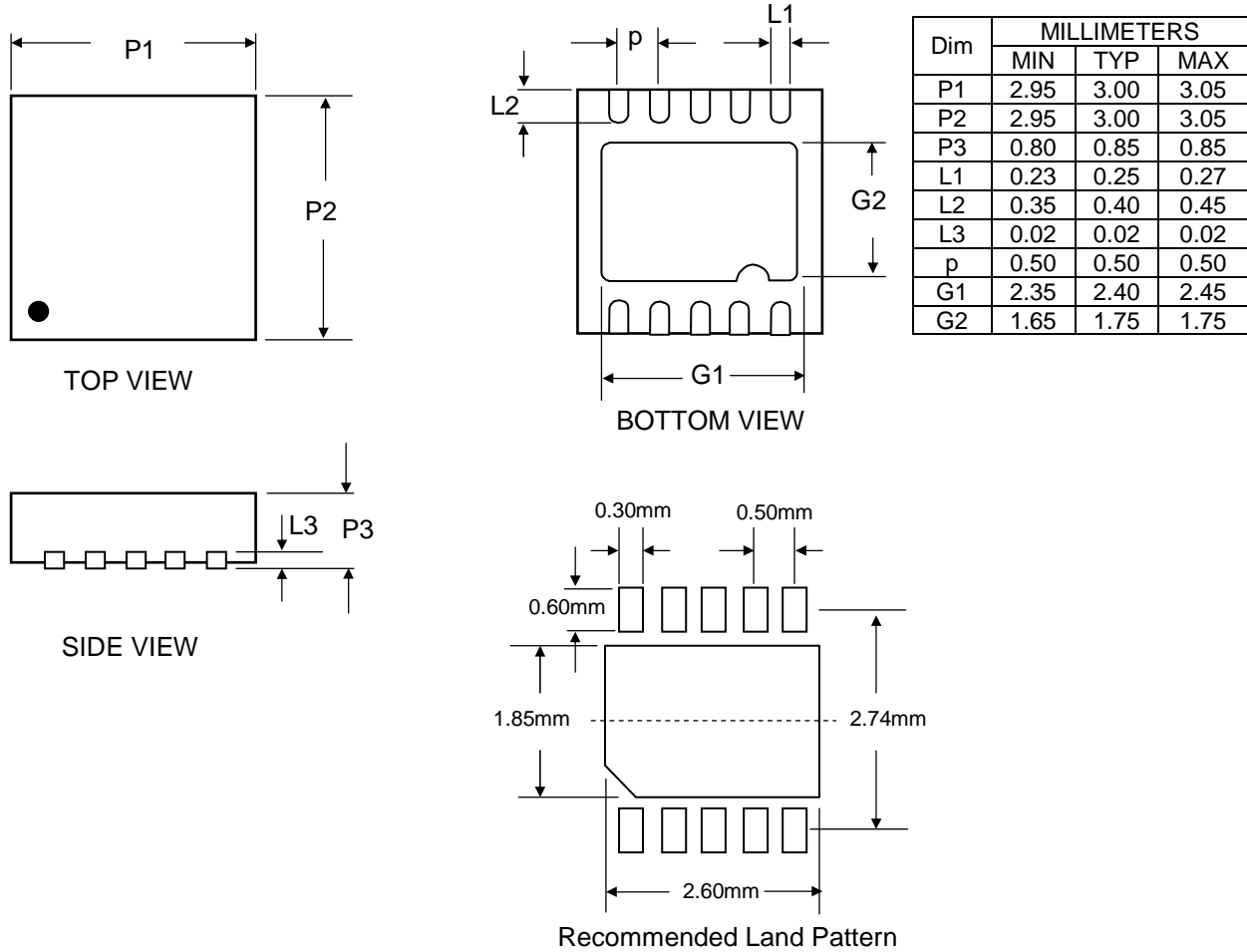

TEMPERATURE PROFILE FOR INFRARED OR CONVECTION REFLOW

